

SymLine® is a Brand of



SymLine®
Chemical Waste Systems

**THE BEST STRATEGY
FOR LIQUID WASTE!**



MADE IN GERMANY.

20 years of experience in safe handling of liquid waste.

www.SymLine.de

SymLine® is a Brand of

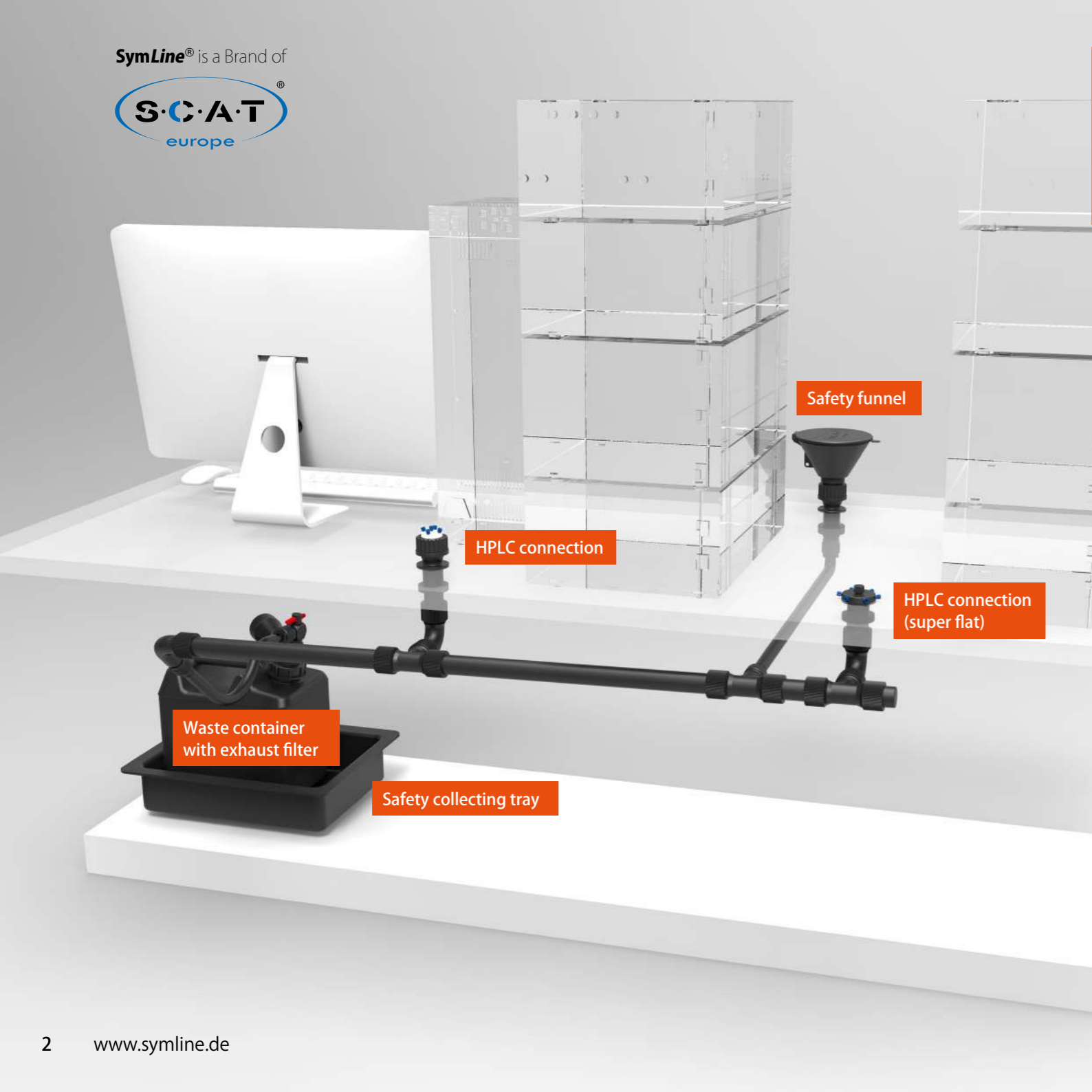

„My individual system for any laboratory.“

Environmental protection, more free space, less hazards at your workplace - the SymLine® system integrates directly into your laboratory furniture. Waste containers are stored outside your working space. For more safety, comfort and sustainable pollution control.

Perfectly synchronised parts and devices make handling of waste liquids as safe as never before. Whether in laboratories, technical centres or production plants - SymLine® has the right components for sustainable liquid waste management.

SymLine®
Chemical Waste Systems





„Efficient protection
for myself and for my
environment!“

Electrostatic conductive plastics are lightweight and permit safe grounding of the components against electrostatic charge and static sparking.

The SymLine® safety system offers multiple options to counteract vapours that emerge during active disposal of liquid waste.



- ✓ *Electrostatic conductive plastics*
- ✓ *Protection against solvent vapours*
- ✓ *ATEX-Approval*
- ✓ *Active storage, in line with regulations*

SymLine®
Chemical Waste Systems

SymLine® is a Brand of





„Simple backfitting für optimum performance.“

SymLine® components fit perfectly into your present laboratory concept, irrespective of the manufacturer, furniture brand or generation of your laboratory furniture.

Shorten your working distances - install the devices in any desired position within your fume cupboard or on your working desktop.

In this way, you can now dispose liquid waste at the place of its origin, and store it where permitted: ideally within safety cabinets. Your work will be more efficient and safe, without accident hazards on your way to the waste container.

- ✓ Flexible installation
- ✓ Fume cupboard, wall or desktop fixation
- ✓ Centrally stored waste container
- ✓ Short distances

SymLine®
Chemical Waste Systems



„Perfect adaption to my instruments.“

Even HPLC work will be much more comfortable: waste fluids are collected directly via the pipe system, and **without exposure**. Escape of hazardous vapours is reliably prevented. The SymLine® system fits any HPLC instruments and tubing sizes.

Your workspace is now free from disturbing waste containers. This means more free space for your daily tasks, as well as better protection for yourself and your laboratory operators.

SymLine®
Chemical Waste Systems



HPLC connection

HPLC waste goes directly into the pipe system. There will not be any disturbing waste containers within your working space - for more safety and larger free working surfaces.



- ✓ *Direct HPLC connection*
- ✓ *No disturbing waste containers*
- ✓ *Vapour prevention*
- ✓ *More free space in your working area*



- ✓ *Intelligent level control*
- ✓ *No waste overflow*
- ✓ *Exhaust filter system*
- ✓ *More time for your core business*



Overview your filling levels safely!

Critical filling levels are displayed optically and acoustically - there will be no flooding waste containers any more, even when stored out of sight. The continuous level control shows exact filling levels in real-time.

„Only the best drive with SymLine®.“

With SymLine®, you need less time to monitor your laboratory waste. You can concentrate on more important tasks, and your work will be much more efficient - thanks to our automated level control. **This way, you will not miss the appropriate moment for container exchange.**

Die continuous level control shows the exact filling levels of your waste containers. This helps you schedule your exchange intervals more easily!

SymLine®
Chemical Waste Systems



More free space in your fume cupboard!

Use the full working space within your fume cupboard for your experimental setup! Safety funnels can be fixed above the desktop, at the rear or side panel. Disturbing waste containers in your fume cupboard are now a thing of the past!



Ignition risks? Not with us!

Pipe system and funnels are made of electrostatic conductive PE-HD. The grounding connection permits safe grounding and prevents static charging and sparking. The respective components are appropriate for use in explosion protected areas.



Endless combinations.

The filling units fit the requirements of the particular workspace. In narrow workspaces, tube connections can be fixed underneath your instruments, e.g. with the super-flat desktop mount (see example).



S.C.A.T. SafetyWasteCaps ensure safety!

Ideal chemical resistance even against aggressive substances such as organic solvents. Fittings for different capillary sizes are included in the scope of delivery.





„Suitable solutions for my individual requirements.“

In close cooperation with you, we develop the customised solution for your laboratory - irrespective of the manufacturer or generation of your laboratory furniture.

Each task is different, each laboratory has its own requirements: this is why the SymLine® installation is as individual as your needs.

Together with our partners, we help choosing and installing the right components - uncomplicated and always on-site.

SymLine[®]
Chemical Waste Systems

CONTACT US!

Phone +49 (0) 6105 / 30 55 86 - 0

... or ask your laboratory planner resp. manufacturer directly for SymLine®!



Competent partner of laboratory furnishers.

Leading laboratory furnishers use our customised solutions for series and special-purpose productions. This example shows the flexible waste tube with direct connection to the lab exhaust air system of the safety cabinet.

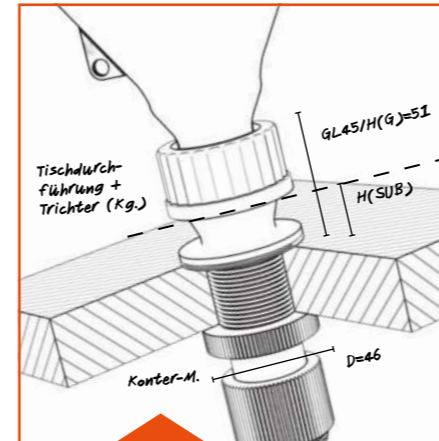

Own development & construction.

Each of our products has been developed as a concrete problem solution for our customers. We construct, develop and manufacture exclusively for practical lab applications. This is why SymLine® always fits like a glove!



SymLine[®]

Chemical Waste Systems

SymLine[®] is a Brand of



S.C.A.T. Europe GmbH
Opelstraße 3
64546 Mörfelden-Walldorf
Germany

Phone +49 (0) 61 05 / 305 586 - 0
Fax +49 (0) 61 05 / 305 586 - 99
e-Mail: info@scat-europe.com
Web: www.scat-europe.com